



Libretto d'istruzioni
Instruction booklet
Notice d'emploi et d'entretien
Betriebsanleitung
Manual de instrucciones



CD

**Diffusore circolare a coni regolabili - Round diffusers with adjustable cones -
Diffuseur circulaire à cônes réglables - Deckenauslass mit Stellkegeln -
Difusor circular con conos regulables**

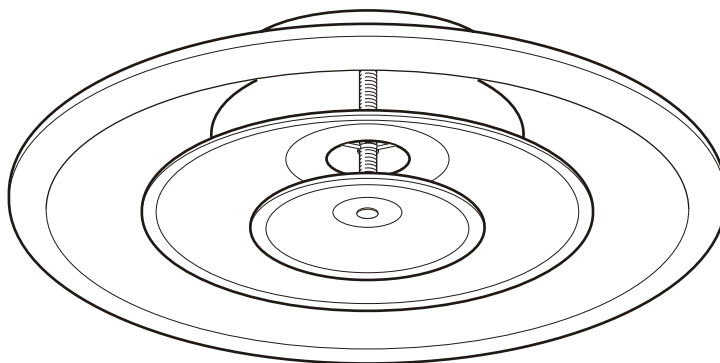

COD. 5.371.084.360

22/02/2007

VORTICE LIMITED
Beeches House - Eastern Avenue
Burton on Trent
DE13 0BB
Tel. (+44) 1283-492949
Fax (+44) 1283-544121
UNITED KINGDOM

VORTICE FRANCE
72 Rue Baratte-Cholet
94106 Saint Maur Cedex
Tel. (+33) 1-55.12.50.00
Fax (+33) 1-55.12.50.01
FRANCE

VORTICE ELETTROSOCIALI S.p.A.
Strada Cerca, 2 - frazione di Zoate
20067 TRIBIANO (MI)
Tel. (+39) 02-90.69.91
Fax (+39) 02-90.64.625
ITALIA

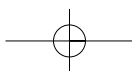

IT

Esecuzione: alluminio verniciato bianco RAL 9010.
Fissaggio: con viti sul collo del diffusore.

DE

Ausführung: Aluminium lackiert Weiß RAL 9010.
Befestigung: Mit Schrauben am Gerätehals.

EN

Construction: aluminium painted in white RAL 9010.
Fixing: with screws on the diffuser neck.

ES

Realizado en: aluminio esmaltado blanco RAL 9010.
Fijación: con tornillos en el cuello del difusor.

FR

Fabrication : aluminium peint blanc RAL 9010.
Fixation : avec vis sur le col du diffuseur.

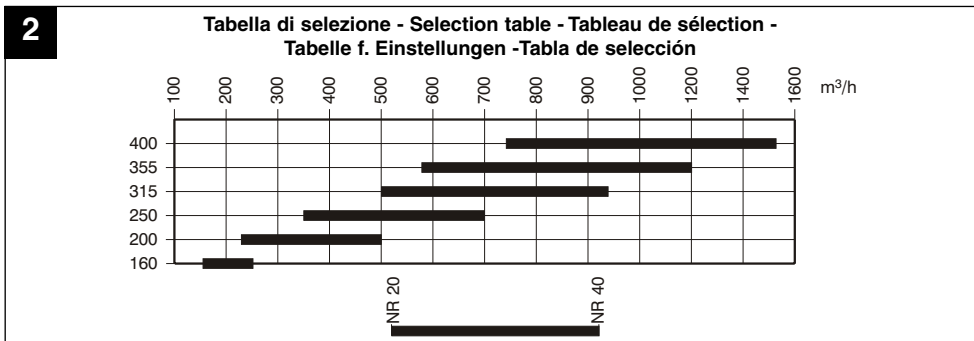
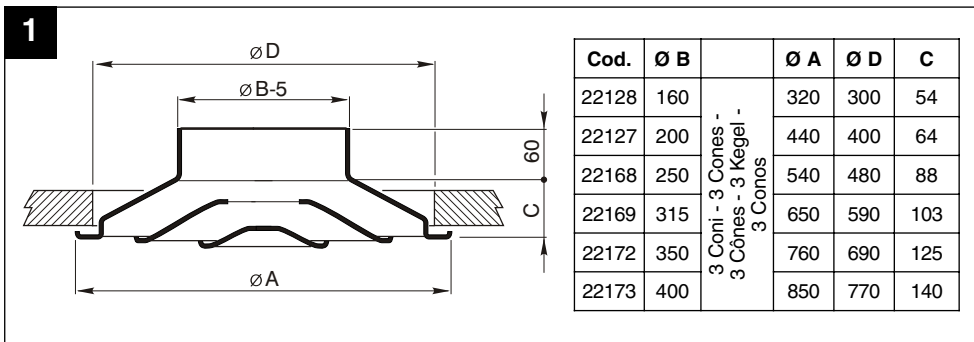

La Vortice S.p.A. si riserva di apportare tutte le varianti migliorative ai prodotti in corso di vendita.
 Vortice S.p.A. reserves the right to make improvements to products at any time and without prior notice.
 La société Vortice S.p.A. se réserve le droit d'apporter toute modification utile à l'amélioration de ses produits en cours de commercialisation.
 Die Firma Vortice S.p.A. behält sich vor, alle eventuellen Verbesserungsänderungen an den Produkten des Verkaufsangebots vorzunehmen.
 Vortice S.p.A. se reserva el derecho de incorporar todas las mejoras necesarias a los productos en fase de venta.