



RESIDENTIAL VENTILATION 

## VORT HRW 20 MONO RANGE

Decentralized heat recovery units

**NEW**





We work to promote life quality  
and to contribute to the social evolution  
through eco-friendly products  
that move air **safely and efficiency.**



[vortice.com](http://vortice.com)





# INDEX



## VORT HRW 20 MONO RC

Decentralized heat recovery units with separate remote control unit

Pag. 4



Code 11634

## VORT HRW 20 MONO

Decentralized heat recovery units with operating controls built into the appliance

Pag. 4



Code 11631

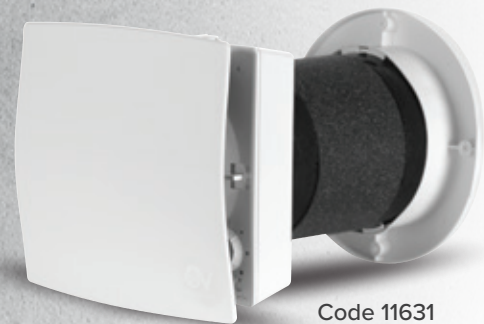

Code 11631

Code 11671

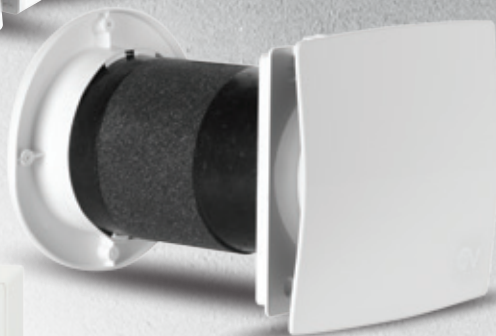

## VORT HRW 20 MONO HCS

Decentralized heat recovery units with operating controls built into the appliance and humidity sensor

Pag. 4

NEW

## VORT HRW 20 MONO D

Decentralized heat recovery units with separate remote control unit and compliant to German regulation

Pag. 10





# VORT HRW 20 MONO RANGE

Decentralized heat recovery units

Decentralized ventilation system with heat recovery, high efficiency, suitable for recessed installation (nominal hole diameters 160 mm) in outside walls of thickness between 300 mm and 700 mm. Quiet, efficient, energy saving and antiallergic (thanks to built-in filters preventing the release of pollutants and allergens into the surrounding air), easy to install and maintain, the VORT HRW 20 MONO, represents the ideal alternative to traditional dual flow centralized ventilation systems.

- 3 models: VORT HRW 20 MONO with operating controls built into the appliance and VORT HRW 20 MONO RC with separate Remote Control unit and VORT HRW 20 MONO HCS.
- Expanded polypropylene (PPE) enclosure.
- Inner panel made of V0 self-extinguishing aesthetic plastic polymer (ABS), clad with heat-insulating material.
- EC brushless motor affording high performance and extremely low power consumption; mounting bracket with ball bearings.
- Accumulator heat exchanger made of ceramic material, high efficiency.
- 5 selectable speeds.
- 3 operating modes for both versions: ventilation with heat recovery; with stale air extraction only; with fresh air supply only.
- Moulded rubber outer grille, which can be mounted externally with masonry plugs, or inserted internally through the hole prepared in the wall with no need for external scaffolding.
- Separate insect mesh, positionable in the duct together with the external grille at the moment of installation.
- Stale internal air extracted around the perimeter of the front panel.
- Outlet port of circular section, nominal diameter 160 mm.
- Washable G3 filter, easily accessible for maintenance purposes.
- Factory-prepared for wall wiring.
- Diagnostics and filter status Leds.
- HCS models are equipped with a relative humidity sensor (four threshold values: 60%, 70%, 80%, 90%, can be set at installation), which automatically start the extraction mode at max speed when indoor relative humidity exceeds the pre-set limit.
- Possibility of operation in automatic mode, enabled by installing optional temperature and relative Humidity sensors.
- Protection rating: IPX4.
- Insulation class: II .

VORT HRW MONO  
(code 11634)

VORT HRW MONO HCS  
(code 11631)

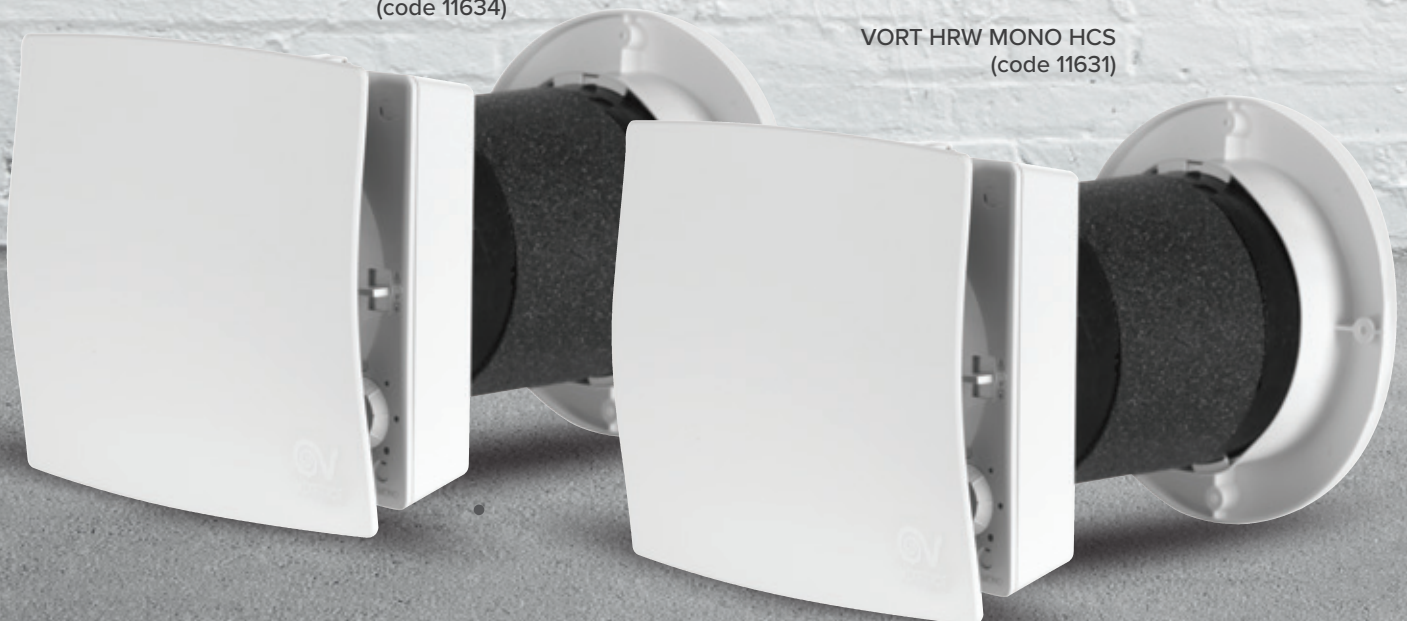





VORT HRW MONO RC  
(code 11635)





# VORT HRW 20 MONO RANGE

Decentralized heat recovery units

## KEY FEATURES

- Elegant aesthetics, perfectly fitting in the residential.
- Small indoor dimensions (240 x 224 x 95 mm version equipped with on-board commands, 240 x 224 x 64 mm version controlled through wired control box).
- Five airflows comprehended in the range between 10 m<sup>3</sup>/h and 38 m<sup>3</sup>/h, to allow the best compromise among performances, consumptions and noise emissions.
- Very low consumptions ( $\leq 2$  W when running at Min speed,  $\leq 5$  W when at Max speed), compatible with continuous operation.
- Low noise levels (16 dB(A) at Min speed according to DIN 52210-6), compatible. with use in studies, bedrooms, living rooms, etc.
- High values of heat transfer efficiency (90% at minimum flow rate according to EN 308), to grant the comfort of users.
- Easy to install, set and use.
- No need to install systems for removal of condensate.
- Wired control box integrating the power supply (no external device needed), allowing switching on/off and selection of operating mode. Up to 4 products can be wired simultaneously to 1 controller.
- Complying with the requirements of Regulation N° 1253/2016/UE set out by the EUP/ErP Directive, effective starting from 01.01.2018.



Rubber made grille, to easy mount from outside or even from inside, without any scaffolding.

High efficiency ceramic made heat accumulator.

Inner panel made of V0 self-extinguishing

Mesh, to be inserted in the duct together with the external grille at installation.

High efficiency EC motor extremely low power consumption

**CONTROL PANEL VORT HRW 20 MONO AND VORT HRW 20 MONO HCS**

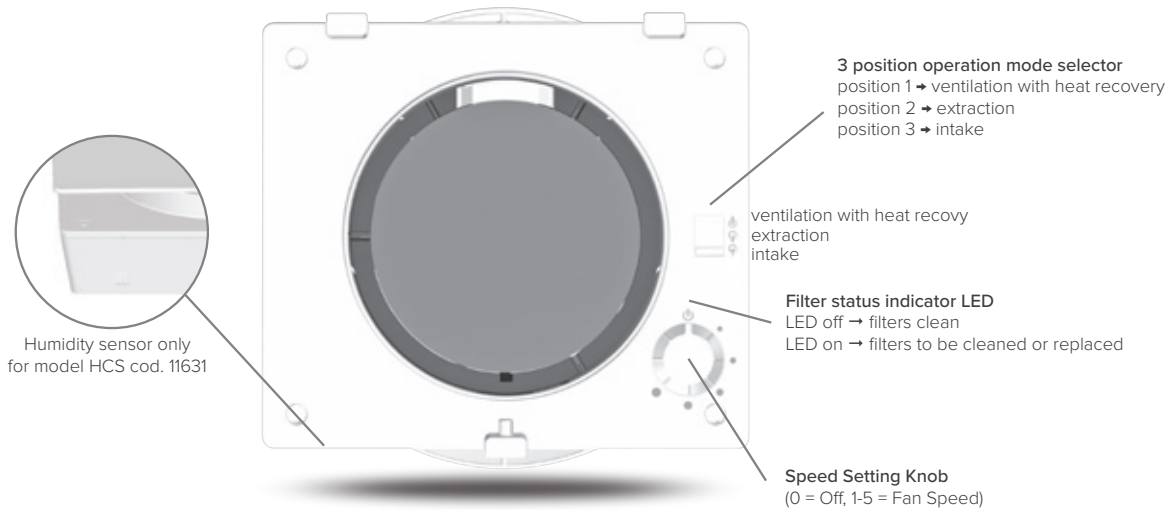

**REMOTE CONTROL VORT HRW 20 MONO RC**

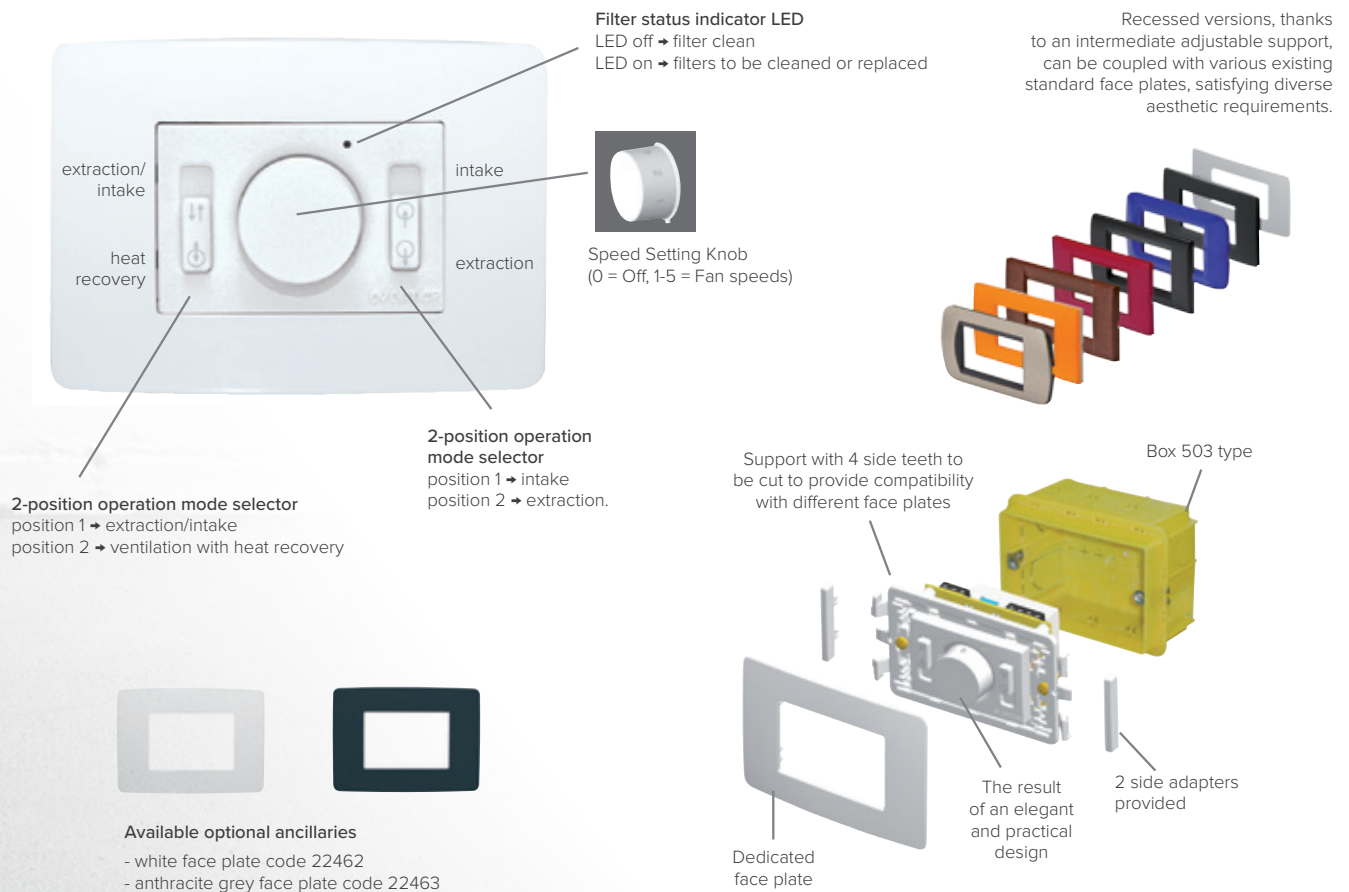





# VORT HRW 20 MONO RANGE

Decentralized heat recovery units

## TECHNICAL DATA

MODELS	CODE	V ~ 50/60 Hz	W		A		MAX AIRFLOW		MAX PRESSURE		Lp dB(A)* 3 m	°C max	Kg
			min/max	min/max	m <sup>3</sup> /h min/max	l/s min/max	mmH <sub>2</sub> O min/max	Pa min/max					
VORT HRW 20 MONO	11634												2.55
VORT HRW 20 MONO RC	11635	220-240	1.0 5.5	0.015 0.053	10.0 40.0	2.77 11.10	0.64 4.10	6.22 40.60	<16.0 23.6	30			2.25
VORT HRW 20 MONO HCS	11631												2.60

## ENERGY DATA

Code	Unit of measurement	VORT HRW 20 MONO HCS	VORT HRW 20 MONO	VORT HRW 20 MONO RC
		11631	11634	11635
Supplier's name or trade mark	-	Vortice	Vortice	Vortice
Specific Energy Consumption class SEC in average climate zone	-	NA*	NA*	NA*
Specific Energy Consumption class SEC average	-	- 37.2	- 37.2	- 37.2
Specific Energy Consumption class SEC cold	kWh/m <sup>2</sup> year	- 80.8	- 80.8	- 80.8
Specific Energy Consumption class SEC warm	-	- 12.3	- 12.3	- 12.3
Declared typology	-	URVU*	URVU*	URVU*
Type of drive	-	VSD**	VSD**	VSD**
Type of heat recovery system HRS	-	regenerative	regenerative	regenerative
Thermal efficiency of heat recovery at reference air flow	%	90	90	90
Maximum flow rate [m <sup>3</sup> /s]	m <sup>3</sup> /h	31	31	31
Electric power input of the fan drive, including any motor control equipment, at maximum flow rate	W	5.1	5.1	5.1
Sound power level LWA	LWA [dB(A)]	44	44	44
Reference flow rate	m <sup>3</sup> /s	0.006	0.006	0.006
Reference pressure difference	Pa	19	19	19
SPI***	W/(m <sup>3</sup> /h)	0.23963	0.23963	0.23963
Control factor CTRL	-	1	1	1
Control typology	-	manual	manual	manual
Maximum internal leakage rates	%	NA*	NA*	NA*
Maximum external leakage rates	%	NA*	NA*	NA*
Mixing rate	-	NA*	NA*	NA*
Position and description of visual filter warning	-	NA*	NA*	NA*
Airflow sensitivity to pressure variations at + 20Pa and - 20 Pa	-	0.27	0.27	0.27
Indoor/outdoor air tightness	m <sup>3</sup> /h	NA*	NA*	NA*
Annual electricity consumption (AEC)	kWh electricity/year	330	330	330
AHS average Annual heating saved	-	4550	4550	4550
AHS cold Annual heating saved	kWh primary energy/year	8901	8901	8901
AHS warm Annual heating saved	-	2057	2057	2057

\*URVU: Unidirectional Residential Ventilation Unit

\*\*VSD: Variable Speed Drive

\*\*\*SPI: Specific Power Input

NA: data not applicable



PERFORMANCE CURVES

VORT HRW 20 MONO cod. 11634 - 11635 - 11631

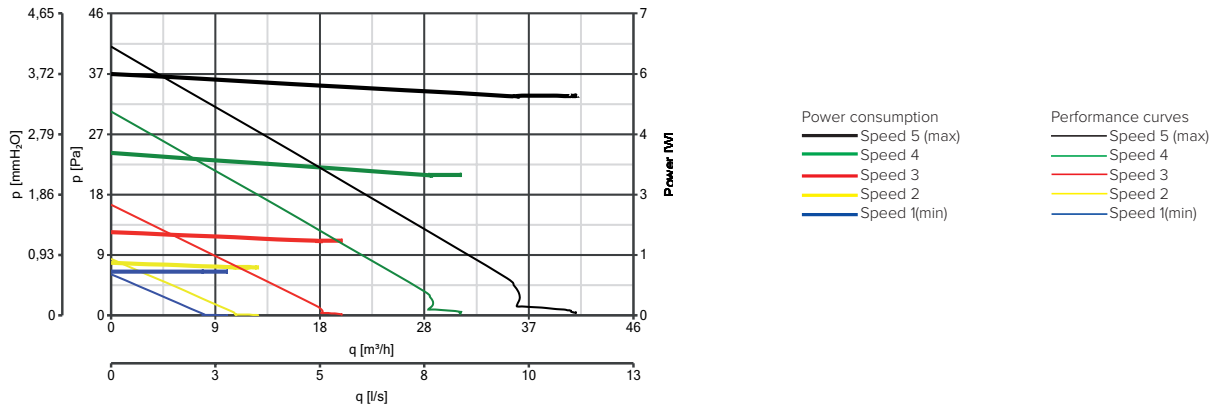

DIMENSIONS

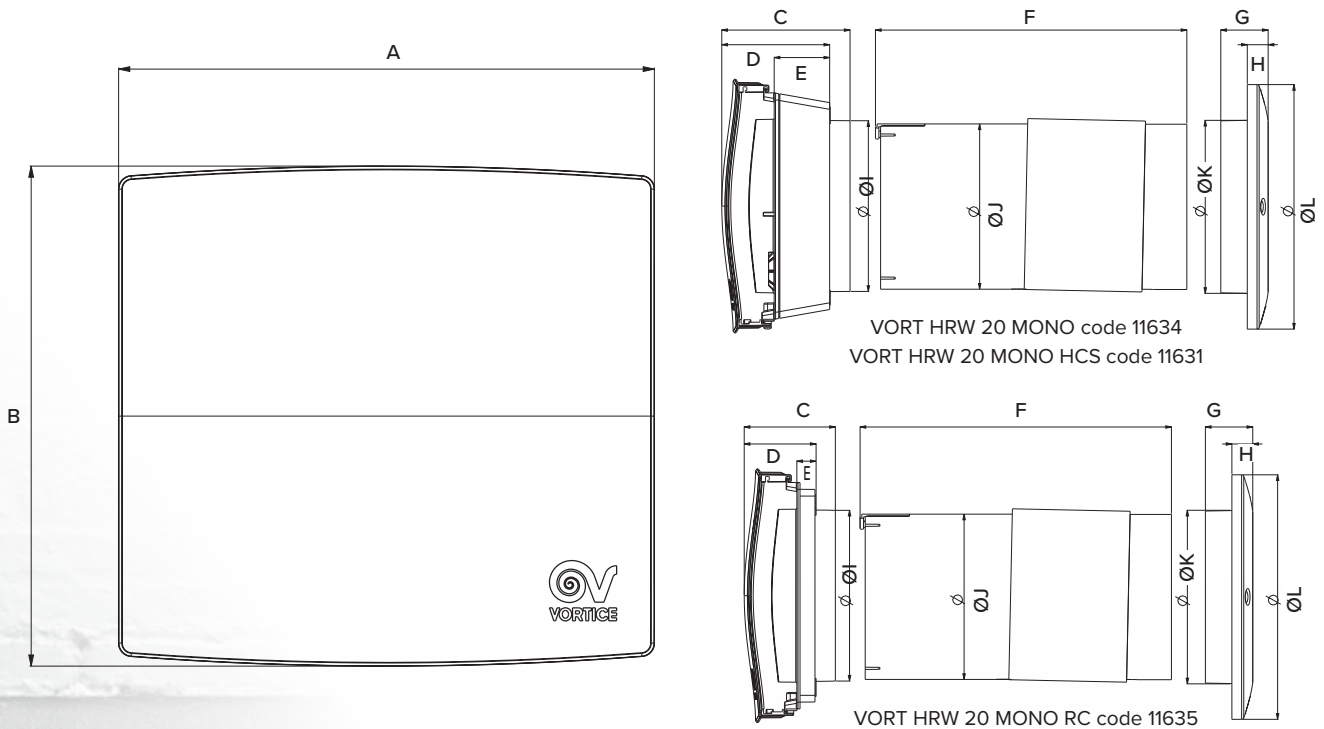

MODELS	CODE	A	B	C	D	E	F	G	H	Ø I	Ø J	Ø K	Ø L
VORT HRW 20 MONO	11634			113	95	49							
VORT HRW 20 MONO RC	11635	240	224	80	64	17	275	42	18	151	146	153	216
VORT HRW 20 MONO HCS	11631			113	95	49							

Dimensions (mm)





# VORT HRW 20 MONO D

NEW

Decentralized heat recovery units

Decentralized ventilation system with heat recovery, high efficiency, suitable for recessed installation (nominal hole diameters 160 mm) in outside walls of thickness between 300 mm and 700 mm. Quiet, efficient, energy saving and antiallergic (thanks to built-in filters preventing the release of pollutants and allergens into the surrounding air), easy to install and maintain, the VORT HRW 20 MONO D (code 11671), represents the ideal alternative to traditional dual flow centralized ventilation systems.

- Recessed wall-mount installation with housing made of expanded polypropylene (PPE).
- Internal panel made of self-extinguishing plastic polymer (ABS V0), coated with heat-insulating material to avoid condensation and designed without frontal vents so as to blend effortlessly into the interior decor (peripheral intake and outlet vents). Provision made for chased wiring.
- External grille made of plastic resin, complete with fly screen.
- Fan unit with EC motor, guaranteeing ultra low energy usage, powered at low voltage and with shaft mounted on ball bearings to ensure virtually "maintenance free" operation. 5 fan speeds, favouring selection of the best balance between volume of air handled, power consumption and noise level.
- High efficiency storage heat exchanger, made of ceramic honeycomb material designed to maximize the heat exchange surface.
- G3 filter, mounted in separate frame to facilitate user serviceability, washable and easily accessible for cleaning and maintenance.
- Mesh prefilter housed adjacent to the external grille.
- Wired remote control unit supplied as standard accessory (code 21145), wall-mounted and compatible with DIN standard circular back box, diameter 60 mm. Complete with circuit board designed for use in combination with three alternative power adapters (optional), in versions for recessed mounting or panel installation (DIN rail) and designed to serve a maximum of 4 or 6 products, the control unit includes 2 Leds (indicating the operational status of the product and warning when the filter is clogged) and is factory prepared for use in combination with IR remote control.
- Protection rating: IPX4.
- Insulation class: II .

VORT HRW 20 MONO D  
(code 11671)











# VORT HRW 20 MONO D

NEW

Decentralized heat recovery units

## KEY FEATURES

- Ultra low power consumption (2.8 W to 8.6 W), perfectly compatible with operation 24/7.
- High heat exchange efficiency (up to 89%), certified by independent body, guaranteeing comfort and minimal waste of energy.
- Extremely low noise levels, compatible with installation in livingrooms (lounge, study, bedroom), and use during the night.
- Offering compact dimensions, plus ease of installation and set-up, these VORT HRW 20 MONO D units are ideal both for new buildings and for renovation projects.
- Wide range of alternative operating modes, allowing selection of the best balance between performance, power consumption and noise levels.
- Simple and intuitive to use.
- Ventilation duct with damper mechanism, to prevent the risk of contaminants entering from outside and maximize heat insulation in the event that the room will not be occupied for extended periods.
- Facility of operation in conjunction with an extractor fan, to ensure continuous and correct ventilation of the dwelling.
- Option of operation in automatic mode, enabled by installing temperature and relative humidity sensors (optional).
- Possibility of installation on outside walls of thickness between 300 mm and 700 mm (with optional accessory).
- Operation permissible across a wide range of outdoor temperatures (-20° / 50° C).





## TECHNICAL DATA

VORT HRW 20 MONO D code 11671					
Speed	1	2	3	4	5
Supply/extract airflow at different speed levels m <sup>3</sup> /h	9	16	25	33	36
Sound pressure breakout LPA dB(A)*	24,5	26,9	32,8	38,9	44,5
Fan power W	2	2,7	3,7	5,0	5,6
Heat recovery efficiency	up to 89%				
Supply voltage V	input 230 V - 50/60 Hz /output 12 V				
Nominal current A	0,026	0,035	0,048	0,056	0,057
Weight Kg	2,55w				
Temperature Max C°	-20° C / 50° C				

\* Sound pressure measurement was performed according to UNI EN ISO 3741:2010

## ENERGY DATA

	Code	Unit of measurement	VORT HRW 20 MONO D
			11671
Supplier's name or trade mark	-	-	Vortice
Specific Energy Consumption class SEC in average climate zone	-	-	NA*
Specific Energy Consumption class SEC average	-	-	- 40,2
Specific Energy Consumption class SEC cold	-	kWh/m <sup>2</sup> year	- 83,4
Specific Energy Consumption class SEC warm	-	-	2,5
Declared typology	-	-	URVU*
Type of drive	-	-	VSD**
Type of heat recovery system HRS	-	-	regenerative
Thermal efficiency of heat recovery at reference air flow	-	%	89
Maximum flow rate [m <sup>3</sup> /s]	-	m <sup>3</sup> /h	32
Electric power input of the fan drive, including any motor control equipment, at maximum flow rate	-	W	5,1
Sound power level LWA	-	LWA [dB(A)]	44,6
Reference flow rate	-	m <sup>3</sup> /s	25
Reference pressure difference	-	Pa	19
SPI***	-	W/(m <sup>3</sup> /h)	0,12598
Control factor CTRL	-	-	1
Control typology	-	-	manual
Maximum internal leakage rates	-	%	NA*
Maximum external leakage rates	-	%	NA*
Mixing rate	-	-	NA*
Position and description of visual filter warning	-	-	NA*
Airflow sensitivity to pressure variations at + 20Pa and - 20 Pa	-	-	0,27
Indoor/outdoor air tightness	-	m <sup>3</sup> /h	NA*
Annual electricity consumption (AEC)	-	kWh electricity/year	174
AHS average Annual heating saved	-	-	4515
AHS cold Annual heating saved	-	kWh primary energy/year	2732
AHS warm Annual heating saved	-	-	2042

\*URVU: Unidirectional Residential Ventilation Unit

\*\*VSD: Variable Speed Drive

\*\*\*SPI: Specific Power Input

NA: data not applicable





# VORT HRW 20 MONO D

NEW

Decentralized heat recovery units

## PERFORMANCE CURVES

VORT HRW 20 MONO D code 11671

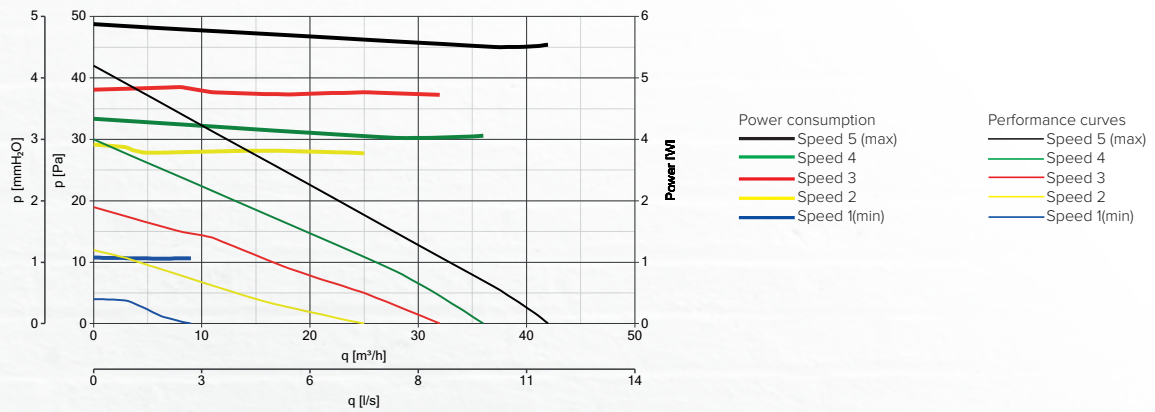

## DIMENSIONS

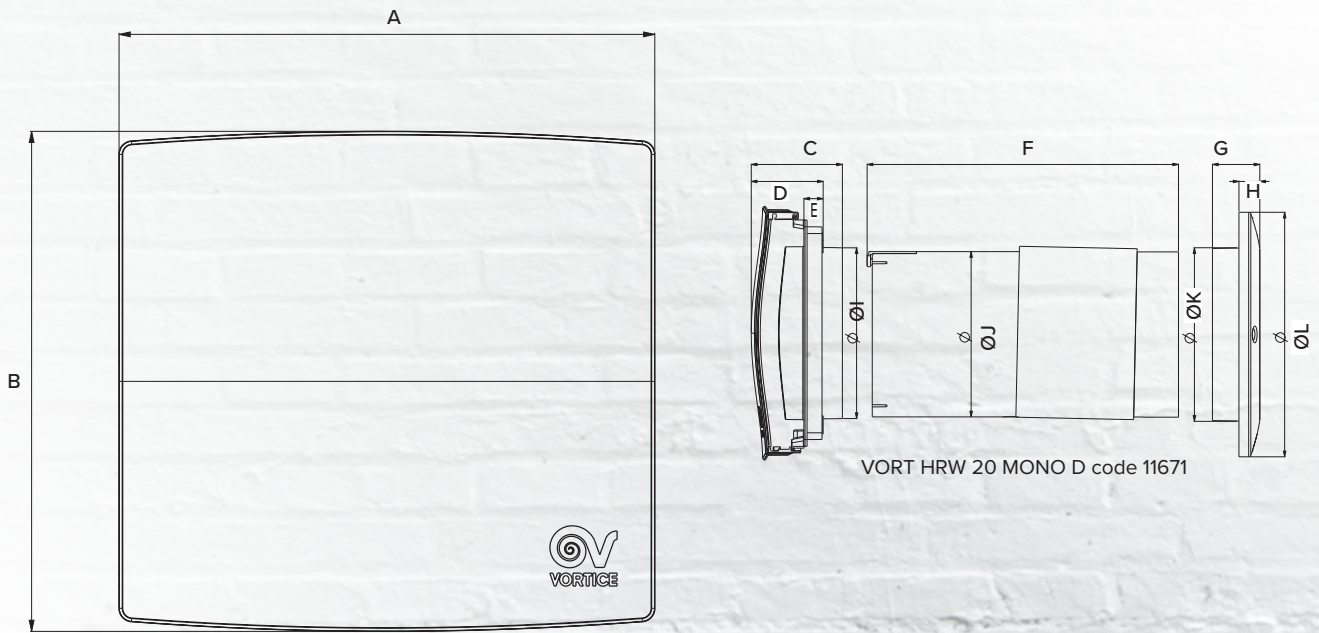

MODELS	CODE	A	B	C	D	E	F	G	H	Ø I	Ø J	Ø K	Ø L
VORT HRW 20 MONO D	11671	240	224	80	64	17	275	42	18	151	146	153	216

Dimensions (mm)



ACCESSORIES ON REQUEST FOR ALL MODELS



C TEMP - code 12992  
Temperature sensor



C HCS - code 12994  
Humidity sensor



M5 filter - code 22699  
Filter



HRW PVC Tube - code 22599  
PCV tube Ø 160 mm  
Length from 400 to 700 mm



RGR - code 21190  
Flexible grille  
no external scaffolding

ACCESSORIES ON REQUEST FOR VORT HRW MONO RC code 11635



HRW RC - code 12993  
Remote unit control



Built-in box - code 22732  
Built-in box for code 12993



Box 503 - code 22461  
Flush mounting box 503

ACCESSORIES ON REQUEST FOR VORT HRW MONO D code 11671

HRW RCD D - code 21145  
Remote control

Mode Selection:  
 → extraction  
 → Normal ventilation  
 (without heat recovery)  
 → Heat recovery



Filter status indicator LED:  
 LED off → filter clean;  
 LED on → filters to be cleaned or replaced

Speed selection

Boost speed



PS24W - code 21187  
Power supply for wall  
mounting - up to 4 units



PS36W - code 21188  
Power supply for wall  
mounting - up to 6 units



PS36WDIN - code 21189  
Power supply for electrical  
panel (DIN bar) - up to 6 units



C SMOKE - code 12993  
Smoke sensor



MWS - code 21148  
Metallic outer grille



WA - code 21191  
Adapter circular/rectangular  
for window grille mounting



WSG-W - code 21193  
Rectangular grille for WA kit  
white finish



WSG-INOX - code 21192  
Rectangular grille for WA kit  
stainless steel



Cod. 5.170.084.915

05/17

Vortice Elettrosociali S.p.A  
Strada Cerca, 2  
Frazione di Zoate  
20067 Tribiano (Milano)  
Tel. (+39) 02 906991  
Fax (+39) 02 90699314  
Italia  
[www.vortice.com](http://www.vortice.com)

Vortice France  
15-33, Rue Le Corbusier  
CS 30007  
94046 Créteil Cedex  
Tél. (+33) 1.55.12.50.00  
Fax (+33) 1.55.12.50.01  
France  
[www.vortice-france.com](http://www.vortice-france.com)

Vortice Limited  
Beeches House-Eastern  
Avenue Burton on Trent  
DE13 0BB  
Tel. (+44) 1283-49.29.49  
Fax (+44) 1283-54.41.21  
United Kingdom  
[www.vortice.ltd.uk](http://www.vortice.ltd.uk)

